



CHARCOAL OVENS

MODEL M50 ST STAND-ALONE OVEN

STANDARD FEATURES

- 3-in-1 application: oven, grill and smoker
- Recommended for up to 150 seat capacity
- 30 % faster than open BBQ grill
- 40% less charcoal usage than open BBQ grill
- Fastest fire-up time among competitors
- Uniform heat yield across the entire coal load
- Controlled bottom air intake simplifies switching between peak and slow dayparts
- Highly efficient low temp cooking (“low and slow”)
- Cooking chamber made of premium heat resistant black steel or 304 stainless steel depending on operator’s preferences
- Proprietary dry spark arrestor designed to ensure long-term safe operation and reduce cleaning and maintenance time
- Ash drawer equipped with a convenient cover for easy removal and cleaning

INCLUDED ACCESSORIES: (2) grates 33”x29”, ember poker, grill brush, food tongs, warming tray

OVEN GRATE

33” x 29”



TECHNICAL INFORMATION

- PRODUCT OUTPUT: 245 LB/HR
- GRATE SIZE: 33” x 29”
- FIRE UP TIME: 30 MIN AVERAGE
- MAX WORK TEMP: 670 F
- CHARCOAL LOAD: 35-44 LBS
- CHARCOAL LOAD DURATION: 8 HR
- OVEN FOOTPRINT: 42.5”W x 39”D
- INSTALLATION HEIGHT: 78”
(WITH SPARK ARRESTOR)
- NET WEIGHT: 924 LBS
- SHIPPING WEIGHT: 977 LBS

Phone: (401) 331-2299
Email: info@bestaovens.com
www.bestaovens.com





CHARCOAL OVENS

MODEL M50 ST STAND-ALONE OVEN

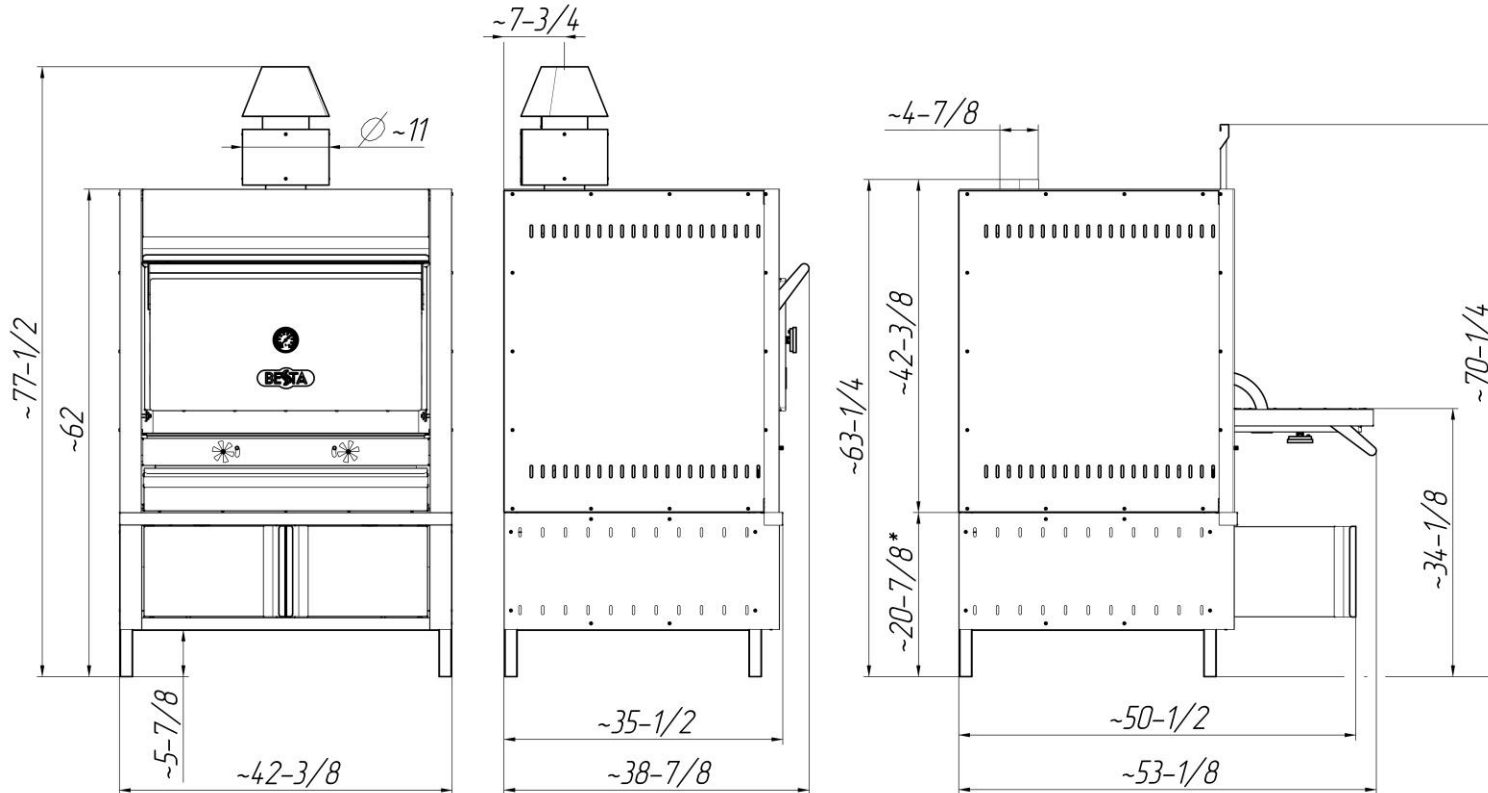

INSTALLATION CLEARANCE

- To combustible surfaces: 3" each side and back

Phone: (401) 331-2299
Email: info@bestaovens.com
www.bestaovens.com

